

TM 11-4920-209-14

DEPARTMENT OF THE ARMY TECHNICAL MANUAL

OPERATOR, ORGANIZATIONAL, AND FIELD MAINTENANCE MANUAL

TABLE SCORSBY

T100925

ADAPTER SCORSBY

T100945

(SPERRY)

HEADQUARTERS, DEPARTMENT OF THE ARMY

AUGUST 1962

TECHNICAL MANUAL

OPERATOR, ORGANIZATIONAL, AND FIELD MAINTENANCE MANUAL

TABLE, TILTING, GYRO INSTRUMENT TESTING MX-4042/ASW-12(V)

TM 11-4920-209-14 }
 CHANGES No. 1 }

HEADQUARTERS,
 DEPARTMENT OF THE ARMY
 WASHINGTON 25, D. C., 26 April 1963

TM 11-4920-209-14, 14 August 1962, is changed as follows:

Change the title of the manual as shown above.

Change "Table Scorsby" to "tilting table" in the following places:

Page 1, paragraph 1-18, line 1.

Page 2, paragraph 1-25, line 1.

Page 4, paragraph 2-2, line 2.

Paragraph 3-2, line 2.

Paragraph 3-6, line 2.

Paragraph 3-8, line 2.

Page 5, paragraph 4-12, line 3.

Paragraph 4-14, lines 3 and 5.

Paragraph 4-18, note, lines 3 and 4.

Paragraph 4-19, line 1.

Page 10, paragraph 7-2, line 1.

Change "Adapter" to "Adapter Scorsby" in the following places:

Page 5, paragraph 4-5, lines 4 and 9.

Page 7, paragraph 6-4A, line 2.

Page 1, paragraph 1-2. Delete paragraph 1-2 and substitute:

1-2. Scope

a. This manual describes Table, Tilting, Gyro Instrument Testing MX-4042/ASW-12 (V) (tilting table) and covers its operation and maintenance. It includes inspection and lubrication of the equipment, troubleshooting, and maintenance service and inspection procedures.

b. The complete technical manual for this equipment includes TM 11-4920-209-50P.

Add paragraphs 1-2.1 and 1-2.2 after paragraph 1-2:

1-2.1. Index of Publications

Refer to the latest issue of DA Pam 310-4 to determine whether there are new editions, changes, or additional publications pertaining to your equipment. DA Pam 310-4 is an index of current technical manuals, technical bulletins, supply bulletins, lubrication orders, and modification work orders that are available through normal publications supply channels. The index lists the individual parts (-10, -20, -35P, etc.) and the latest changes to and revisions of each equipment publication.

1-2.2. Forms and Records

a. *Reports of Maintenance and Equipment Improvement Recommendations.* Use equipment forms and records in accordance with instructions in TM 38-750.

b. *Report of Damaged or Improper Shipment.* Fill out and forward DD Form 6 (Report of Damaged or Improper Shipment) as prescribed in AR 700-58 (Army), NAVSANDA Publications 378 (Navy), and AFR 71-4 (Air Force).

c. *Comments on Manual.* Forward all comments on this publication direct to Commanding Officer, U. S. Army Electronics Materiel Support Agency, ATTN: SELMS-MP, Fort Monmouth, N. J. DA Form 2028 Recommended Changes to DA Technical Manual Parts Lists or Supply Manuals 7, 8 or 9 will be used.

Paragraph 1-3, lines 1 and 2. Change “The Table Scorsby (figure 1-1)” to The tilting table (fig. 4-1) .

Paragraph 1-5. Add the following after the heading: Table, Tilting, Gyro Instrument Testing MX-4042/ASW-12 (V) (fig. 4-1) consists of Adapter Scorsby T-100945 (fig. 6-3) and Table Scorsby T-100925 (Table Scorsby) (fig. 1-1) .

Paragraph 1-21, line 2. Change “figure 1-1” to figure 6-1.

Page 4, paragraph 3-2*f*. Add subparagraph *g* after subparagraph *f*.

g. If the equipment has been used or reconditioned, see whether it has been changed by a modification work order (MWO). If the equipment has been modified, the MWO number will appear on the front panel near the nomenclature plate. Check to see whether the MWO

number (if any) and appropriate notations concerning the modification have been entered in the equipment manual.

Note. Current MWO'S applicable to the equipment are listed in DA Pam 310-4.

Paragraph 3-3, lines 2 and 3. Change “paragraph 5-5” to paragraph 5-11.

Paragraph 3-6, line 6. Change “paragraphs 5-5 through 5-8” to paragraphs 5-11 and 6-8.1.

Page 5, figure 4-1 caption. Change the caption to Table, Tilting, Gyro Instrument Testing MX-4042/ASW-12(V).

Paragraph 4-18, heading. Change TABLE SCORSBY to TILTING TABLE.

Paragraph 4-19, heading. Change TABLE SCORSBY to TILTING TABLE.

Page 6, section V. Delete section V and substitute:

Section V. MAINTENANCE INSTRUCTIONS

5-1. Scope of Maintenance

The maintenance duties assigned to the organizational repairman of Table, Tilting, Gyro Instrument Testing MX-4042/ASW-12 (V) are listed below with a reference to the paragraph covering the specific maintenance function.

a. Daily maintenance service and inspection (par. 5-5).

b. Weekly maintenance service and inspection (par. 5-6).

c. Cleaning (par. 5-7).

d. Monthly maintenance service and inspection (par. 5-9).

e. Cleaning and touchup maintenance instructions (par. 5-10).

f. Lubrication (par, 5-11).

5-2. Tools and Materials Required for Maintenance

a. *Tools*. Tool Kit, Radar and Radio Repairman TK-87/U and Tool Kit, Supplementary, Radar and Radio Repair TK-88/U contain all the tools necessary to maintain the tilting table.

b. *Materials*.

(1) Cleaning Compound (Federal stock NO. 7930-395-9542).

Warning: Cleaning compound is flammable and its fumes are toxic. Do not use near an open flame; provide adequate ventilation.

(2) Cleaning cloth.

(3) Lubricating Oil (OAI) (Federal stock No. 9150-257-5449) .

(4) Grease, Aircraft and Instrument (GL) (Federal stock No. 9150-261-8298).

(5) Fine sandpaper.

(6) Touchup paint.

5-3. Preventive Maintenance

Preventive maintenance is the systematic care, servicing, and inspection of equipment to prevent the occurrence of trouble, to reduce downtime, and to assure that the equipment is serviceable.

a. *Systematic Care*. The procedures given in paragraphs 5-5 through 5-11 cover systematic care essential to proper upkeep and operation of the equipment. The cleaning operations

(par. 5-7) should be performed once a day. If the equipment is not used daily, however, the cleaning operations must be performed before operation after any extended shutdown, or once a week while the equipment is kept in standby condition. The other items must be checked before the equipment is placed in operation after a shutdown, during operation, or after it is turned off, as specified in the applicable paragraph.

b. Maintenance Service and Inspection. The maintenance service and inspection charts (pars. 5-5, 5-6, and 5-9) outline inspections to be made at specific intervals. These inspections are made to maintain combat serviceability; that is, to maintain the equipment in good general (physical) condition and in good operating condition. To assist operators in maintaining combat serviceability, the charts indicate what to inspect, how to inspect, and what the normal conditions are; the references

column lists the paragraph that contains additional information. If the defect cannot be remedied, higher echelon maintenance or repair is required. Records and reports of these inspections must be made in accordance with TM 38-750.

5-4. Maintenance Service and Inspection Periods

Maintenance service and inspections of the tilting table are required on a daily, weekly, and monthly basis. Paragraph 5-5 specifies services and inspections that must be performed daily. Paragraph 5-6 specifies services and inspections that must be accomplished on a weekly basis. If the equipment is maintained in a standby condition, the daily (par. 5-5) and weekly (par. 5-6) services and inspections should be accomplished at the same time. The maintenance services and inspections that are accomplished on a monthly basis are specified in paragraph 5-9.

5-5. Daily Maintenance Service and Inspection Chart

Note. The items in the following chart are not consecutive. They are taken from the complete monthly maintenance service and inspection chart (par. 6-9).

Item No.	Procedure		References
	Item	Normal condition or result	
1	SET: Inspect the equipment for: a. Completeness ----- b. Cleanliness -----	a. Equipment must be complete ----- b. Exterior of equipment must be clean and dry; free of dirt, dust, grease, and fungus.	a. TM 11-4920-209-56P. b. Par. 6-7.
7	SPIRIT LEVEL: Inspect the spirit levels (9, fig. 1-2) for cracked or broken windows and leaking fluid.	Windows of spirit levels should not be cracked or broken, and the spirit levels should not be leaking fluid.	Fig. 1-2.

5-6. Weekly Maintenance Service and Inspection Chart

Note. The items in the following chart are not consecutive. They are taken from the complete monthly maintenance service and inspection chart (par. 6-9).

Item No.	Procedure		Reference
	Item	Normal condition or result	
1	SET: Inspect the equipment for: preservation.	Painted surfaces must be free of bare spots, rust, and corrosion.	Par. 5-10.
3	MODIFICATION WORK ORDERS : Check DA Pam 310-4 to determine if new applicable MWO'S have been published.	All urgent MWO'S have been applied to the equipment. All routine MWO'S have been scheduled.	Par. 3-2g.

Item No.	Procedure		References
	Item	Normal condition or result	
4	POWER CABLE: Inspect power cable for cuts, cracks, strain, fraying, or deterioration.	Power cable is free of cuts, cracks, strain, fraying, or deterioration.	Fig. 1-1.
6	MOUNTING: Inspect seating and stability of mountings. Check for loose or missing hardware.	All screws, nuts, bolts, and washers are present and properly tightened. Mounting shows no evidence of weakness or deformity.	Fig. 1-2 through 1-4, and 6-1, 6-2, and 6-3.
8	KNOBS, SCREWS, AND SWITCH : Check for proper mechanical action as follows: a. Rotate table leveling screws (1, fig. 1-3), knurled collar (3), locking screw (9), tie rod (8), and stop screw (5, fig. 1-4). b. Rotate knurled collar (3, fig. 1-3) counterclockwise and raise and lower the reversing knob (4). c. Operate the power toggle switch (2, fig. 1-3) on and off .	a. Action is positive without binding or scraping. b. Same as for a above ----- c. Same as for a above -----	a. Figs. 1-3 and 1-4. b. Fig. 1-3. c. Fig. 1-3.

5-7. Cleaning

Inspect the exterior of the tilting table. The exposed surfaces should be clean and free of dirt, dust, grease, and fungus.

a. Remove dust and loose dirt with a clean dry cloth.

Warning: Cleaning compound is flammable and its fumes are toxic. Provide adequate ventilation. Do not use near a flame.

b. Remove grease, fungus, or ground-in dirt from the exterior of the tilting table. Use a cloth dampened (not wet) with cleaning compound.

c. Clean the Adapter Scorsby and exterior of the Table Scorsby; use a soft clean cloth. If dirt is difficult to remove, dampen the cloth with water; mild soap may be used to make the cleaning more effective.

5-8. Monthly Maintenance

Perform the maintenance functions indicated in the monthly maintenance and inspection chart (par. 5-9) once each month. A month is defined as 30 calendar days of 8-hour-per-day operation. If the equipment is operated 16 hours a day, the monthly maintenance should be performed at 15-day intervals. Adjustment of the maintenance interval must be made to compensate for any unusual operating conditions. Equipment maintained in a standby (ready for immediate operation) condition must have monthly maintenance performed on it. Equipment in limited storage (requires service before operation) does not require monthly maintenance.

5-9. Monthly Maintenance Service and Inspection Chart

Item No.	Procedure		References
	Item	Normal condition or result	
1	SET: Inspect the equipment for: a. Completeness ----- b. Cleanliness -----	a. Equipment must be complete ----- b. Exterior of equipment must be clean and dry; free of dirt, dust grease, and fungus.	a. TM 11-4920-209-50P. b. Par. 5-7.

Item No.	Procedure		References
	Item	Normal condition or result	
	c. Preservation -----	c Painted surfaces must be free of bare spots, rust, and corrosion.	c. Par. 6-10.
2	PUBLICATIONS: See that pertinent publications are available (app).	a. Manual must be complete and in usable condition.	a. App.
		b. All Changes pertinent to the equipment are on hand (DA Pam 310-4) .	b. DA Pam 310-4 for requirements.
3	CODIFICATION WORK ORDERS : Check DA Pam 310-4 to determine if new applicable MWO'S have been published.	c. Depot maintenance repair parts manual is complete and in usable condition.	c. App.
4	POWER CABLE: Inspect power cable for cuts, cracks, strain, fraying, or deterioration.	All URGENT MWO'S have been applied to the equipment. All ROUTINE MWO'S have been scheduled	Par. 3-2g.
5	LUBRICATION: Lubricate the equipment (par. 5-11).	Power cable is free of cuts, cracks, strain, fraying, or deterioration.	Fig. 1-1.
6	MOUNTING: Inspect seating and stability of mountings. Check for loose or missing hardware.	Mechanisms should not show signs of overlubrication or underlubrication, All screws, nuts, bolts, and washers are present and properly tightened, Mounting shows no evidence of weakness or deformity,	Par. 5-11. Fig. 1-2 through 1-4.
7	SPIRIT LEVEL: Inspect the spirit levels (9, fig. 1-2) for cracked or broken windows and leaking fluid.	Windows of spirit levels should not be cracked or broken, and the spirit levels should not be leaking fluid.	Fig. 1-2.
8	KNOBS, SCREWS, AND SWITCH : Check for proper mechanical action as follows:		
	a. Rotate table leveling screws (1, fig. 1-3), knurled collar (3), locking screw (9), tie rod (8), and stop screw (5, fig. 1-4) .	a. Action is positive without binding or scraping.	a. Fig. 1-3 and 1-4.
	b. Rotate knurled collar (3, fig. 1-3) counterclockwise and raise and lower reversing knob (4).	b. Same as for a above -----	b. Fig. 1-3.
	c. Operate power toggle switch (.2, fig. 1-3) on and off.	c. Same as for a above -----	c. Fig. 1-3.
9	TABLE TILTING:		
	a. Loosen the stop screw (5, fig. 1-4) and the locking screw (9, fig. 1-3), and tilt the table (6) from 0° through 15° as indicated on the scale (10) by pushing down on the edge of the table (6) at the stop screw (5, fig. 1-4) end.	a. The table (6, fig. 1-3) should tilt from 0° through 15° without binding or scraping.	a. Figs. 1-3 and 1-4.
	b. Tilt the table (6, fig. 1-3) to 10° as indicated on the scale (10) and tighten the locking screw (9). Apply an upward and then a downward pressure on the edge of the table (6).	h. The table (6, fig. 1-3) should remain at an angle of 10° as indicated on the scale (10).	b. Fig. 1-3.

Item No.	Procedure		References
	Item	Normal condition or result	
10	c. Loosen the locking screw (9, fig. 1-3) and push up on the edge of the table (G) at the top screw (5, fig. 1-4) end until the scale (10, fig. 1-3) indicates 0°.	c. None observable -----	c. Figs. 1-3 and 1-4.
	TABLE ROTATION:		
	a. Loosen the knurled collar (3, fig. 1-3) and raise the reversing knob (4) to its upper position. Connect the power cable (not shown) to a source of 110-volt, 60-cycle power and set the power toggle switch (2, fig. 1-3) at the on position.	a. The motor (23, fig. 1-2) should operate, and the table (6, fig. 1-3) should rotate in one direction and then it should automatically reverse its direction of rotation.	a. Figs. 1-2 and 1-3.
	b. Set the power toggle switch (2, fig. 1-3) at the off position, and lower the reversing knob (4) to its down position.	b. None observable -----	b. Fig. 1-3.
	c. Set the power toggle switch (2, fig. 1-3) at the on position, and manually rotate the reversing knob (4) in one direction and then in the opposite direction.	c. The table (6, fig. 1-3) should rotate and then change its direction of rotation each time the setting of the reversing knob (4) is changed.	c. Fig. 1-3.
d. Set the power toggle switch (2, fig. 1-3) at the off position, and disconnect the power cable from the power source.	d. None observable -----	d. Fig. 1-3.	

5-10. Cleaning and Touchup Painting Instructions

Remove rust and corrosion from metal surfaces by lightly sanding them with fine sandpaper. Brush two thin coats of paint on the bare metal to protect it from further corrosion. Refer to applicable cleaning and refinishing practices specified in TM 9-213.

5-11. Lubrication

a. Lubrication of the oilcups, shaft of reversing switch, ball joints, and gears of the Table Scorsby must be performed each month. A month consists of 30 days of normal 8-hour operation. If the equipment is operated more than 8 hours a day, the lubrication intervals should be adjusted accordingly. For example, if the equipment is operated 16 hours a day

instead of 8, lubricate the equipment every 15 days instead of every month.

b. To apply oil to the oilcups (3, fig. 1-4), lift the cap of each oilcup and apply 4 to 10 drops of oil to the wick until it is saturated.

c. To apply oil to the shaft of the reversing switch (1, fig. 1-2) and to the ball joints (not shown), dip a piece of wire into the oil to collect a small drop at the end. Transfer the oil to the part by touching the wire to the part.

d. To apply grease to the gears (11, fig. 1-3), remove the half-inch hole-closing cap (not shown) on the right top of the casting (21, fig. 1-2) to expose the gears (11, fig. 1-3). Dip the end of a piece of wire into the grease and transfer the grease to the gears by touching the wire to the teeth of the gears. Rotate the gears while applying the grease.

e. Lubricate the parts of the Table Scorsby as indicated in the following chart:

Application point	Lubricant	Amount
Oilcups (3, fig. 1-14)-----	Oil (OAI)-----	4-10 drops in each oilcup.
Shaft of reversing switch (1, fig. 1-2)-----	Oil (OAI)-----	1 drop.
Ball joints (at each end of tie rod (8, fig. 1-3)-----	Oil (OAI)-----	1 drop on each ballpoint.
Gears (11, fig. 1-3)-----		

Page 7, paragraph 6-4A, heading. Change “THE ADAPTER” to ADAPTER SCORSBY T-100945.

Paragraph 6-8. Add paragraph 6-8.1 after paragraph 6-8.

6-8.1. Lubrication of Internal Parts

At each 2-year period, lubricate the tilting table as follows:

a. Disassemble the tilting table (par. 6-4 through 6-7).

b. Disassemble the motor (23, fig. 1-2) until the bearings are accessible,

c. Clean the motor bearings (not shown), reversing switch fork, table bearing surface

of the headplate, gears, table retaining screw (10, fig. 1-2), and the star wheel (2, fig. 1-4) with a brush dipped in cleaning compound.

d. Pack the motor bearings (not shown) with grease (GL). Reassemble the motor.

e. Apply a thin coat of grease (GL), to the reversing switch fork (not shown), the teeth of all gears, and to the star wheel (2, fig. 14). Replace the motor in the casting (par. 6-9).

f. Apply a thin coat of grease (GL), to the table bearing surface (not shown) on the headplate, and to the head of the table retaining screw (10, fig. 1-2). Replace the table (par. 6-10).

Page 10. Add the following after section VII:

APPENDIX
REFERENCES

Following is a list of applicable references that are available to the operator and organizational and field maintenance personnel of Table, Tilting, Gyro Instrument Testing MX-4042/ASW-12(V).

DA Pam 310-4	Index of Technical Manuals, Technical Bulletins, Supply Bulletins, Lubrication Orders, and Modification Work Orders.
TM 9-213	Painting Instructions for Field Use.
TM 38-750	The Army Equipment Record System and Procedures.
TM 11-4920-209-50P	Depot Maintenance Repair Parts and Special Tool Lists: Table, Tilting, Gyro Instrument Testing MX-4042/ASW-12(V).

By Order of the Secretary of the Army:

Official:

J. C. LAMBERT,
Major General, United States Army,
The Adjutant General.

EARLE G. WHEELER,
General, United States Army,
Chief of Staff.

Distribution:

To be distributed in accordance with DA Form 12-31 requirements for operator and crew maintenance instructions for all fixed wing and rotor wing aircraft.

TECHNICAL MANUAL }
 No. 11-4920-209-14 }

HEADQUARTERS,
 DEPARTMENT OF THE ARMY
 WASHINGTON 25, D. C., 14 August 1962

Operator, Organizational, and Field Maintenance Manual

TABLE SCORSBY T100925
 ADAPTER SCORSBY T100945
 (SPERRY)

Section		Page
I	INTRODUCTION AND DESCRIPTION	1
	1-1. Introduction	1
	1-4. Description	1
	1-24. Principles of Operation	2
II	SPECIAL SERVICE TOOLS	4
III	PREPARATION FOR USE, STORAGE, OR SHIPMENT	4
IV	OPERATION INSTRUCTIONS	4
	4-1. Preliminary Adjustment, Alignment, and Warm-Up	4
	4-4. Connections	4
	4-8. Starting and Stopping the Equipment	5
	4-10. Purpose and Use of Operating Controls	5
	4-18. Typical Operating Instructions for the Table Scorsby	5
	4-33. Precautions	6
V	PERIODIC INSPECTION, MAINTENANCE, AND LUBRICATION	6
	5-1. Periodic Inspection	6
	5-3. Maintenance	6
	5-5. Lubrication	6
	5-9. Cleaning	7
VI	TROUBLE SHOOTING	7
	6-1. Trouble Shooting	7
	6-3. Removal and Replacement Procedures	7
	6-11. Repair	8
VII	CALIBRATION	10

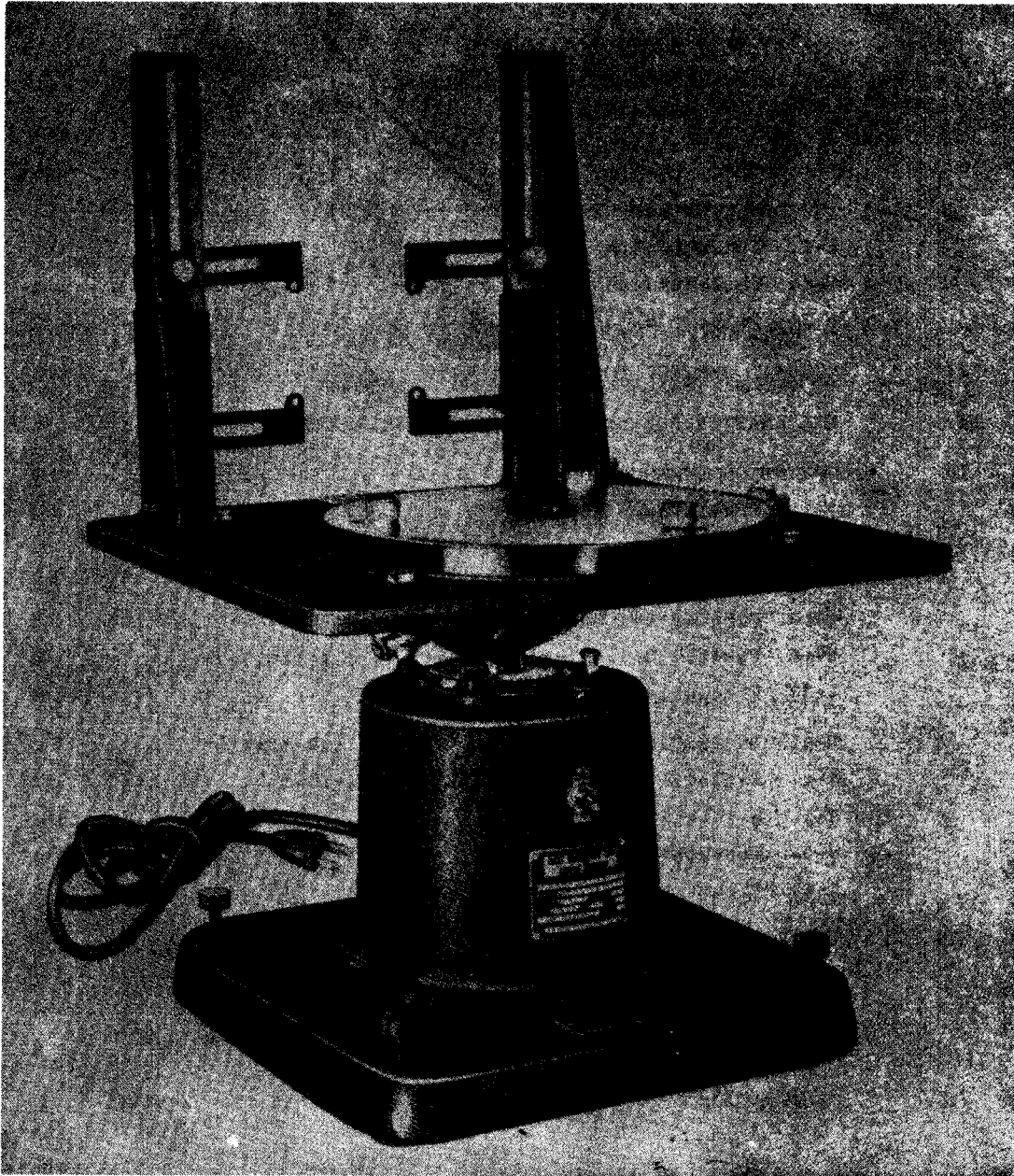

Figure I-I. Table Scorsby T-100925

SECTION I

INTRODUCTION AND DESCRIPTION

1-1.

1-2. **SCOPE OF HANDBOOK.** This handbook contains operation and service instructions for the Table Scorsby T-100925 (AF Stock No. 7CAC-793550) and the Adapter Scorsby T-100945 (AF Stock No. 7CAC-0029-86). This equipment is supplied by Sperry Gyroscope Company Division of Sperry Rand Corporation, Great Neck, New York. The Table Scorsby, Model No. 1406R, manufactured by the Ideal Laboratory, Tool and Supply Company, Cheyenne, Wyoming, includes a Universal Mount manufactured by Sperry.

1-3. **PURPOSE OF EQUIPMENT.** The Table Scorsby (figure 1-1) has two functions: it can impart Scorsby motion to the equipment mounted on it, or it can function as a turntable. When it functions to develop Scorsby motion, it oscillates in known amounts of roll, pitch, and yaw. Under these conditions, the extent of the effect of static friction inherent in gyroscope assemblies can be determined. When the unit functions as a turntable, the Universal Mount rotates at an approximate speed of six rpm.

1-4. DESCRIPTION.

1-5. **GENERAL DESCRIPTION.** The Table Scorsby consists essentially of a motor which drives a table through a linkage. The linkage is such that the table will either rotate or move in a Scorsby motion, whichever is desired. The Universal Mount is screwed to the table, thus receiving the same motion that is applied to the table.

1-6. DETAILED DESCRIPTION.

1-7. TABLE SCORSBY.

1-8. LINKAGE FROM MOTOR TO TABLE.

1-9. The motor gear (20, figure 1-2), attached to the motor shaft (19), drives the head drive gear (18) through a series of intermediate gears. The head drive gear is screwed to the bottom of the head bearing shaft (15).

1-10. The center block (8) is held against the collar (14) and is attached to the head bearing shaft (15) by the screw (6). The collar bears against the bottom plate (16), which in turn rests on the shoulder of the head bearing shaft. Since a slight clearance exists between the bottom plate and the casting (21), the bottom plate is free to turn with the collar, the center block, the head bearing shaft, and the gearing to the motor shaft.

1-11. The top plate (12) is attached to the two side plates which are held to the center block (8) by the locking screw (7). The side plates bear against the sides of the center block. Thus, as the center block rotates it carries along with it the side and top plates.

1-12. The table (13) is screwed to the centering washer (11) which is held to the top plate (12) by the screw (10). Since the centering washer is not threaded, and since the contacting surfaces of the table, the top plate and the centering washer are bearing sur-

faces, a rigid joint does not exist between the table and the top plate. It is therefore possible to turn the top plate without turning the table.

1-13. **TABLE TILT.** The top surface of the center block (8, figure 1-2) is not completely horizontal. The rear section of this part slants down at a 15-degree angle. Since the center block has a slot rather than a hole for the locking screw (7), the top (12) and side plates, and therefore the table (13), can be tilted to any angle up to the 15-degree limit set by the sloping side of the center block. To tilt the table, loosen the locking screw and press on the edge of the table at the stop-screw end.

1-140 CONNECTIONS FOR SCORSBY MOTION OR TURNTABLE MOTION.

1-15. **SCORSBY MOTION.** To obtain Scorsby motion the table (6, figure 1-3) must be prevented from rotating. By attaching the table tie rod (8) to the ball joint (7, figure 1-4) the table is held to the stationary case. Thus, if the motor is running, the top plate (7, figure 1-3) will rotate but the table (6) will be prevented from turning. If the table is tilted, Scorsby motion results.

1-160 **TURNTABLE MOTION.** To obtain turntable motion remove the tie rod (8, figure 1-3) at the ball joint (7, figure 1-4). If the motor is running, the top plate will rotate, carrying the table with it.

1-17. REVERSING THE TABLE.

1-18. The Table Scorsby incorporates a feature which allows for either automatic or manual reversing of the table. With the reversing knob (4, figure 1-3) in the upper position, the table will automatically reverse every six cycles (approximately every minute). Manual reversal of the table is accomplished by turning the reversing knob when it is in the lower position.

1-19. The reversing knob (4) is held in either the upper or lower position by a ball and spring device. In the upper position of the reversing knob, the switch arm (1, figure 1-4), which is attached to the shaft of this knob, meshes with the star wheel (2). The star wheel is rigidly attached to the knurled collar (3, figure 1-3). The star wheel is driven by a series of gears to the motor shaft. Since the switch arm operates the reversing switch, lifting the knob to the upper position allows the motor to actuate the reversing switch (1, figure 1-2), thus achieving automatic reversal of the table.

1-20. When the reversing knob (4, figure 1-3) is in the lower position, it does not mesh with the star wheel (2, figure 1-4). Thus, the switch arm (1) is disconnected from the motor shaft (19, figure 1-2) and automatic reversing cannot occur. By manually turning the reversing knob, however, the switch arm will operate the reversing switch.

1-21. UNIVERSAL MOUNT.

1-22. The Universal Mount is screwed to the Table Scorsby as shown in figure 1-1. There are two methods

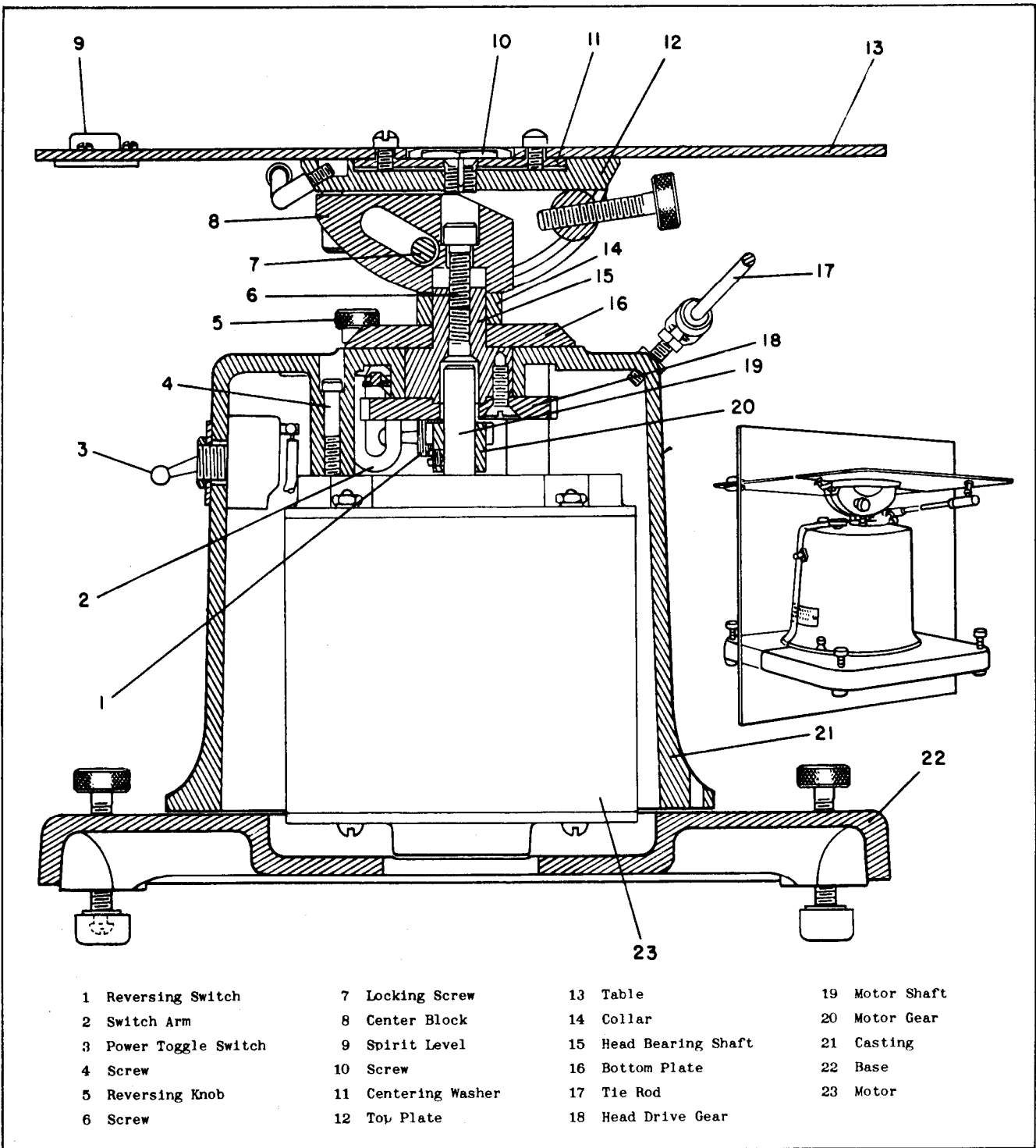

Figure 1-2. Sectional View - Table Scorsby

for mounting instruments on the mount. A turntable attached to the base of the mount has three screw holes for attaching the Vertical Gyro Control or the Directional Gyro Control (Slaved). Four adjustable arms on the mount allow for attachment of gyroscopic instruments which are normally mounted in a horizontal plane.

1-23. The turntable may be turned to set the instrument mounted on it to any desired heading. A Camloc locks the turntable in the turned position.

1-24. PRINCIPLES OF OPERATION.

1-25. DEVELOPMENT OF SCORSBY MOTION. The Table Scorsby will produce Scorsby motion when the tie rod (9, figure 1-3) is connected to the table (6) and the table is tilted. As the motor rotates, its motion is transmitted through the linkage to the top plate (12, figure 1-2) which also turns. However, since the table tie rod is linked to the table by a tie rod terminating in ball joints (7, figure 1-4), rotation of the tilted

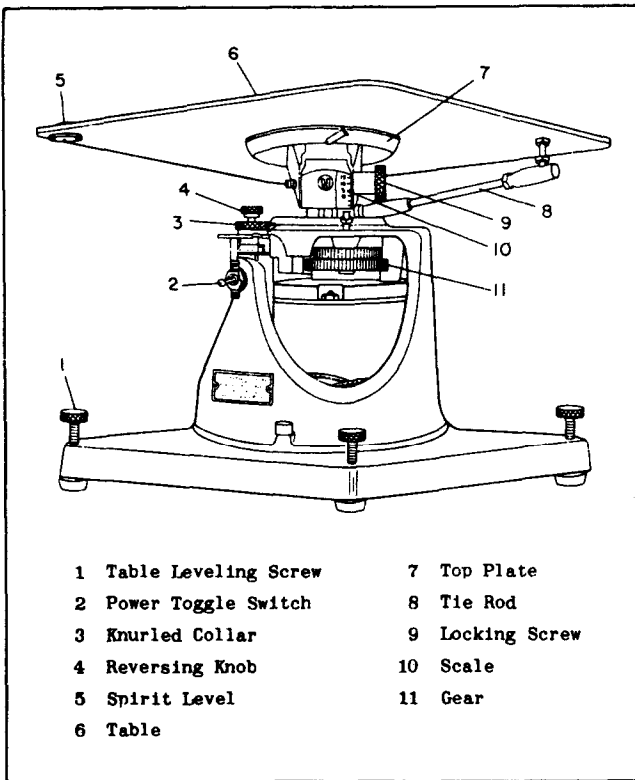

Figure 1-3. Sectional View - Table Scorsby (Right Side)

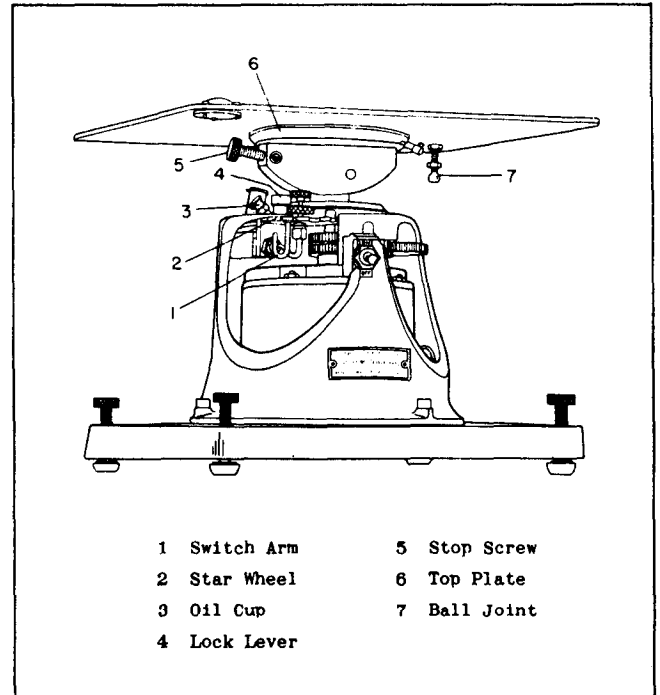

Figure 1-4. Sectional View - Table Scorsby (Left Side)

top plate (12, figure 1-2) under the table results in nutation of the table.

1-26. **REVERSING THE MOTOR.** (See figure 1-5.) Changing the direction of motor rotation is accomplished by reversing the phase relationship between the voltages

to the two motor windings. Since the voltages appearing across the two motor windings originate at the same 110-volt, 60-cycle source, the voltage at the winding, which is in series with the resistance-capacitance combination, leads the voltage at the second winding. This results in motor rotation in one direction. When the reversing switch operates and connects the resistance-capacitance combination to the second motor winding, motor rotation occurs in the opposite direction.

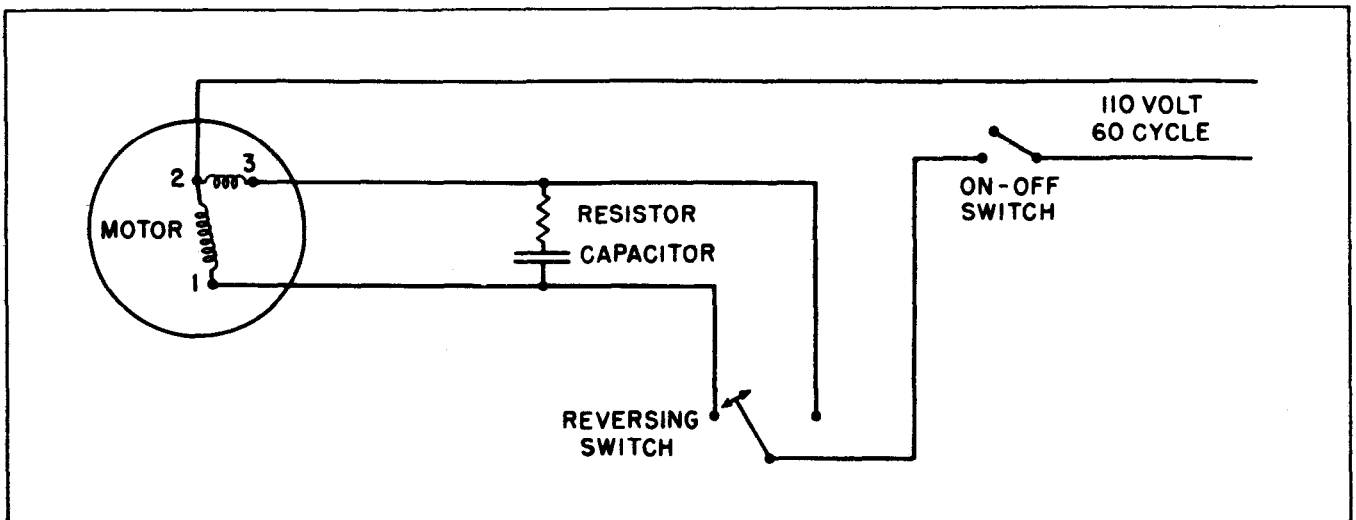

Figure 1-5. Electrical Schematic of Motor and Reversing Switch

SECTION II SPECIAL SERVICE TOOLS

2-1. SPECIALSERVICE TOOLS.

2-2. No special service tools are required to service the Table Scorsby T-100925.

SECTION III PREPARATION FOR USE, STORAGE, OR SHIPMENT

3-1. PREPARATION FOR USE.

3-2. **UNPACKING.** The following procedure should be followed to remove the Table Scorsby T-100925 from the crate in which it is shipped.

- a. Cut the steel bands which are wrapped around the crate.
- b. Open the moisture-vapor barrier bag.
- c. Remove the bags of silica-gel.
- d. Take out the nuts and lock washers which secure the unit to the crate.
- e. Remove the unit from the crate.
- f. Clean the unit.

3-30 **LUBRICATION.** Check the unit to make sure there is sufficient lubricant present. (Refer to paragraph 5-5.)

3-4. **POWERSUPPLYREQUIRED.** The Scorsby Table requires a source of 110-volt, 60-cycle, a-c power.

3-5. PREPARATION FOR STORAGE.

3-6. There is no special storage procedure. If, however, the Table Scorsby is to be stored in a particularly humid location and corrosion prevention is necessary, refer to the removal procedures (paragraph 6-3). Then lubricate as indicated in paragraphs 5-5 through 5-8.

3-7. PREPARATION FOR SHIPMENT.

3-8. There are no special shipping instructions for the Table Scorsby. The unit should be crated and protected by a moisture-vapor barrier bag according to standard methods.

SECTION IV OPERATION INSTRUCTIONS

4-1. PRELIMINARY ADJUSTMENT, ALIGNMENT, AND WARM-UP.

4-2. Set the table of the Table Scorsby T-100925 in the horizontal position. Adjust the four screws (1, figure 1-3) to level the Table Scorsby, as indicated by the spirit level.

4-3. No warm-up of the Table Scorsby is necessary. Refer, however, to the instructions in the prime equipment handbook for such warm-up time as may be required by the gyroscopic instrument under test.

4-4. CONNECTIONS.

4-5. **MECHANICAL.** If a Vertical Gyro Control or a Directional Gyro Control (Slaved) is to be tested, the unit can be mounted on the turntable of the Universal Mount. (See figure 4-1.) The unit under test can be set to the required headings by unlocking the Camloc of the Universal Mount and turning the turntable. The Camloc is locked to secure the unit in position. If a gyroscopic instrument, which is normally mounted in a horizontal position, is to be tested, the four adjustable arms (figure 4-1) of the Universal Mount are set

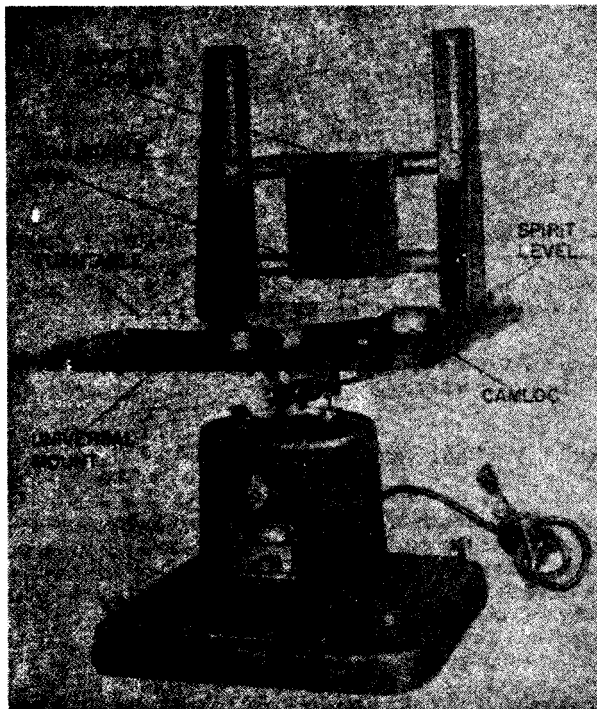

Figure 4-1. Side View of Table Scorsby Showing Turntable

to correspond to the mounting holes of the gyro instrument. The unit is then secured to the arms. If it is desired to test the gyroscopic instrument in a vertical position, an Adapter, T-100945 (AF Stock No. 7CAC-0029-86), must be employed. (See figure 4-1.) Attach the Adapter to the adjustable arms of the Universal Mount, T-100930, with the four knurled-head screws provided. Mount the Vertical Gyro Control on the Adapter securing it with two knurled-head screws provided.

4-6. **ELECTRICAL.** The Table Scorsby is connected to a source of 110-volt, 60-cycle a-c power. The instrument mounted on the Universal Mount can then be connected to its test equipment.

4-7. **UNIT UNDER TEST.** Refer to the instructions in the prime equipment handbook for specific connection and power requirements for the unit under test.

4-8. STARTING AND STOPPING THE EQUIPMENT.

4-9. A power toggle switch (2, figure 1-3) is provided for starting and stopping the motor of the Table Scorsby.

4-10. PURPOSE AND USE OF OPERATING CONTROLS.

4-11. **TIEROD.** The tie rod (8, figure 1-3) when connected to the ball joint (7, figure 1-4) prevents the table (6, figure 1-3) from turning. If the table is tilted and the motor is running, Scorsby motion will result.

4-12. **TABLE LEVELING SCREWS AND SPIRIT LEVEL.** The four table leveling screws (1, figure 1-3) are provided to enable the Table Scorsby to be leveled, as indicated on the spirit level (5).

4-13. **POWER TOGGLE SWITCH.** The power toggle switch (2, figure 1-3) is provided to control the application of

power to the motor. When the switch is "ON" the motor runs.

4-14. **REVERSING KNOB.** The reversing knob (4, figure 1-3) is provided to allow either the automatic or manual reversing features of the Table Scorsby to be utilized. By loosening the knurled collar (3) and lifting up the reversing knob, the Table Scorsby can be set to reverse automatically every six cycles (approximately once a minute). The direction of rotation of the table may be reversed at any time by moving the knob to the lower position, and then turning it.

4-15. **TABLE TILT AND STOP SCREW.** By pushing on the edge of the table at the stop screw (5, figure 1-4) end, the Table Scorsby may be tilted to any angle up to 15 degrees. The scale (10, figure 1-3) on the center block is provided to indicate the angle of tilt. By setting the table to the desired angle and then turning the stop screw in, the table, if leveled, may then be returned to the angle set by the stop screw.

4-16. **LOCKINGSCREW.** The locking screw (9, figure 1-3) is provided so that when it is tightened it will hold the table (6) in the position to which it is tilted. By exerting a force of eight pounds on the edge of the table, however, the hold of the locking screw may be overpowered.

4-17. **FRICTION LOCK.** The friction lock feature is utilized to lock the head to the casting. To operate the friction lock, press out and back on the lock lever (4, figure 1-4).

NOTE

The lock lever should be released when power is supplied to the motor. If this is not done, an unnecessary load is placed on the motor.

4-18. TYPICAL OPERATING INSTRUCTIONS FOR THE TABLE SCORSBY.

NOTE

In the following section a general, though typical example is given to illustrate a function of the Table Scorsby. For detailed step-by-step test procedures involving the Table Scorsby, refer to the latest Operation and Service handbooks on the prime equipments.

4-19. **FUNCTION OF THE TABLESCORSBY.** The Table Scorsby imparts roll, pitch, and yaw motion to equipment mounted on it. This is known as Scorsby motion.

4-20. **EXAMPLE OF TABLE SCORSBY SUPPLYING ROLL, PITCH, AND YAW TO GYROSCOPIC INSTRUMENTS.**

4-21. **CONNECTIONS.** Connect the Table Scorsby to a source of 110-volt, 60-cycle, a-c power. Connect the unit under test, in this case the Vertical Gyro Control, in accordance with instructions in the note of paragraph 4-4.

4-22. **BALANCE TEST (DRIFT).**

4-23. The effect of the earth's rotation on drift rate varies with latitude although it is the same for corresponding degrees north and south latitude. Therefore, during this drift test, consideration should be given to the latitude in which the repair depot is located. Attach the Vertical Gyro Control to the turntable of the Universal Mount. Place a 3/16-inch plug under the base mounting foot at the forward end, and one under the mounting foot to the right of the forward foot. Place the switches on the "ANALYZER - VERTICAL GYRO, AND COMPASS CONTROL", T-100803, in the

following positions: "S-1", "ON"; "S-2", "SLOW"; "S-3", "V.G."; "S-4", "AIL. SYN."; "S-5", "OFF"; "S-6", "OFF"; "S-7", "RUN". Connect the leads from the vtvm to the jacks "J & R" and "T" on the test fixture. This will check the drift about the roll axis.

4-24. Turn the Table Scorsby so that the "FORWARD" mark on the frame and Synchro cap is toward north.

4-25. Displace the Table Scorsby 7-1/2 degrees from the horizontal by pressing on the edge of the table (6, figure 1-3). Be sure the stop screw (5, figure 1-4) is unscrewed sufficiently to permit the desired tilt. Connect the tie rod (8, figure 1-3) to the ball joint (7, figure 1-4).

4-26. Start the Table Scorsby by moving the power toggle switch (2, figure 1-3) to the "ON" position. Place switch of the Analyzer in the "FAST" position. Allow the gyro to settle, that is, the maximum voltage on the vtvm reached on each oscillation of the Table Scorsby should be the same.

4-27. The Table Scorsby should oscillate at a rate of five to seven cycles per minute.

4-28. Turn the "V.G. & GYROSYN TORQUERS" switch "S-2" to the "SLOW" position and note the maximum

vtvm reading reached after the gyro has again settled. Record the reading.

4-29. Turn the "S-5" to "C.F. ON". Simultaneously turn switch "S-2" to "OFF" and start the electric timer.

4-30. After a two-minute interval, record the change in the maximum reading of the vtvm. Turn switch "S-5" to "OFF".

4-31. Compute the drift by noting the difference between the two readings. An increase in the voltage reading denotes a westerly drift. The drift must be within the tolerances specified.

4-32. Turn the power toggle switch to "OFF" to stop the Table Scorsby.

4-33. PRECAUTIONS.

4-34. If the Table Scorsby motor hums when it is turned on, it should be turned off immediately, otherwise it will burn out. If this occurs, investigate for defective wiring, binding gears, or lack of lubricant. (Refer to paragraph 5-5.)

SECTION V

PERIODIC INSPECTION, MAINTENANCE, AND LUBRICATION

5-1. PERIODIC INSPECTION.

5-2. **ONE-MONTH INSPECTION.** Once a month inspect the Table Scorsby T-1 00925 as follows:

a. Tilt the table. Operate the motor unit until the scale on the center block (8, figure 1-2) is towards the front. Test the table to see that it can be tilted and held in position by the locking screw (9, figure 1-3).

b. Check that the stop screw (5, figure 1-4) can be turned in and out.

c. Check that the automatic reversing knob (4, figure 1-3) can be raised and lowered. The knurled collar (3), under the reversing knob, can be rotated to allow the reversing knob to be raised and lowered.

d. Lifting the reversing knob (4, figure 1-3) to the upper position should automatically reverse the table. Putting the reversing knob in the lower position should make the table run in only one direction. Change the direction of rotation by manually rotating the reversing knob in either direction.

5-3. MAINTENANCE.

5-4. No maintenance other than lubrication is required.

5-5 LUBRICATION.

5-6. **ONE-MONTH PERIOD.** The following lubrication can be performed without dismantling the Table Scorsby:

a. Fill the three oilcups (3, figure 1-4) around the head of the Table Scorsby with a very light, acid-

free mineral oil that will not gum, such as aircraft instrument lubricating oil, Specification MIL-L-6085A. Each of these oil cups has a wick to absorb and hold the oil. Four to 10 drops may be required to saturate these wicks.

b. A drop of oil, Specification MIL-L-6085A, should be put around the shaft of the reversing switch (1, figure 1-2). A drop of oil should be put on each ball joint (7, figure 1-4) at both ends of the tie rod.

c. Using a knife blade, lift out the half-inch, hole-closing cap on the right top of the housing. Place a small quantity of light-bodied grease, such as aircraft and instrument grease, Specification MIL-G-3278, on the teeth of the two gears seen through this hole. Rotate the gears while greasing. The total quantity of grease to be applied should equal approximately a 1/4-inch ball. Close the hole by pressing the cap back into place.

5-7. **TWO-YEAR PERIOD.** At each two-year period it will be necessary to relubricate the motor ball bearings and the reversing-switch mechanism. (Refer to the removal and replacement procedures described in paragraph 6-3.)

5-8. PARTS TO BE LUBRICATED.

a. Open the motor and pack the bearings with a light-bodied, high-quality grease, aircraft and instrument grease, Specification MIL-G-3278.

b. Apply a coat of grease, Specification MIL-G-3278, to the reversing-switch fork and to the star wheel (2, figure 1-4). Also coat the teeth of all gears with this grease.

c. Coat the table bearing surface of the headplate with a small quantity of the grease, and replace the table.

d. Grease the head of the table retaining screw (10, figure 1-2) with the grease specified in the preceding paragraphs.

5-9. CLEANING.

5-10. Remove all dirt and dust at reasonable intervals.

5-11. At the two-year lubrication period, clean the parts which are to be lubricated.

SECTION VI

TROUBLESHOOTING

6-1. TROUBLESHOOTING.

6-2. Table 6-1, Troubleshooting Chart, is provided to list troubles, probable causes, and remedies.

6-3. REMOVAL AND REPLACEMENT PROCEDURES.

6-4. **TO REMOVE THE UNIVERSAL MOUNT.** Remove the four nuts (3, figure 6-1) and the Universal Mount (2).

6-4A. **TO REMOVE THE ADAPTER.** Remove the four knurled-head screws and the Adapter T-100945. (See figure 6-3.)

6-5. TO DISASSEMBLE THE UNIVERSAL MOUNT.

a. Remove the screw (17, figure 6-2) and take off the turntable (16.)

Remove the screw (15) and take off the Camloc

c. Remove the thumb screws (4 and 6) and screw (15), and take off the arms (3).

6-6. TO REMOVE THE TABLE.

a. Using a sharp scribe point, remove the dust cap over the table retaining screw (10, figure 1-2).

b. Loosen the wedge screw in the center of the screw.

c. With a 7/8-inch socket wrench unscrew the hexagon-head screw.

d. With the tie rod (17, figure 1-2) disconnected, lift the table (13) from the top plate (12).

6-7. TO REMOVE THE CASTING AND THE MOTOR.

a. Remove the three screws holding the casting (21, figure 1-2) to the base (22) and lift off the casting.

b. Set the casting on the bench in an upright position, with the weight resting on the bottom of the motor. Using a 5/32-inch Allen wrench, remove the three screws which hold the motor (23).

c. Hold the motor in its position in the casting and turn the entire assembly upside down on the bench (on a cloth to protect the table bearing surface). Lift out the motor without damaging the wiring.

6-8. **ADDITIONAL REMOVAL OF PARTS.** It is now possible to remove any other components, if necessary.

6-9. TO REPLACE THE MOTOR IN THE CASTING.

a. Reassemble the motor (23, figure 1-2) in the casting and place the resistor and wiring around the motor, so that they will not interfere with the base. If the terminals of the capacitor are quite close to the motor case, a piece of insulating material should be inserted between them.

b. Hold the motor in its position in the casting and turn the entire assembly upright on the bench.

c. Using a 5/32-inch Allen wrench, replace the three screws which hold the motor.

TABLE 6-1. TROUBLESHOOTING CHART

TROUBLE	PROBABLE CAUSE	REMEDY
Motor fails to run.	Defective wiring.	Repair wiring.
	Binding Gears.	Check gearing.
Motor chatters.	Binding of head.	Release lock. Lubricate, if required.
Motor fails to reverse.	Reversing knob down.	Pull up the reversing knob (4, figure 1-3).
	Reversing mechanism out of adjustment.	Turn reversing knob manually and adjust spring finger to star wheel.
	Reversing mechanism defective.	Replace damaged parts.
	Resistor or condenser shorted or otherwise defective.	Check and replace damaged parts.
	Reversing switching switch defective.	Install a new switch.

6-10. REPLACING THE TABLE.

a. Replace the table (13) on the top plate (12). Tighten the table retaining screw (10) until the play of the table is almost eliminated. The table must be perfectly free to rotate on the top plate.

b. Tighten the wedge screw in the center of the screw.

c. Replace the dust cap and connect the tie rod.

6-11. REPAIR.

6-12. Except for the replacement of damaged parts, as described in the preceding paragraphs, no repair is necessary.

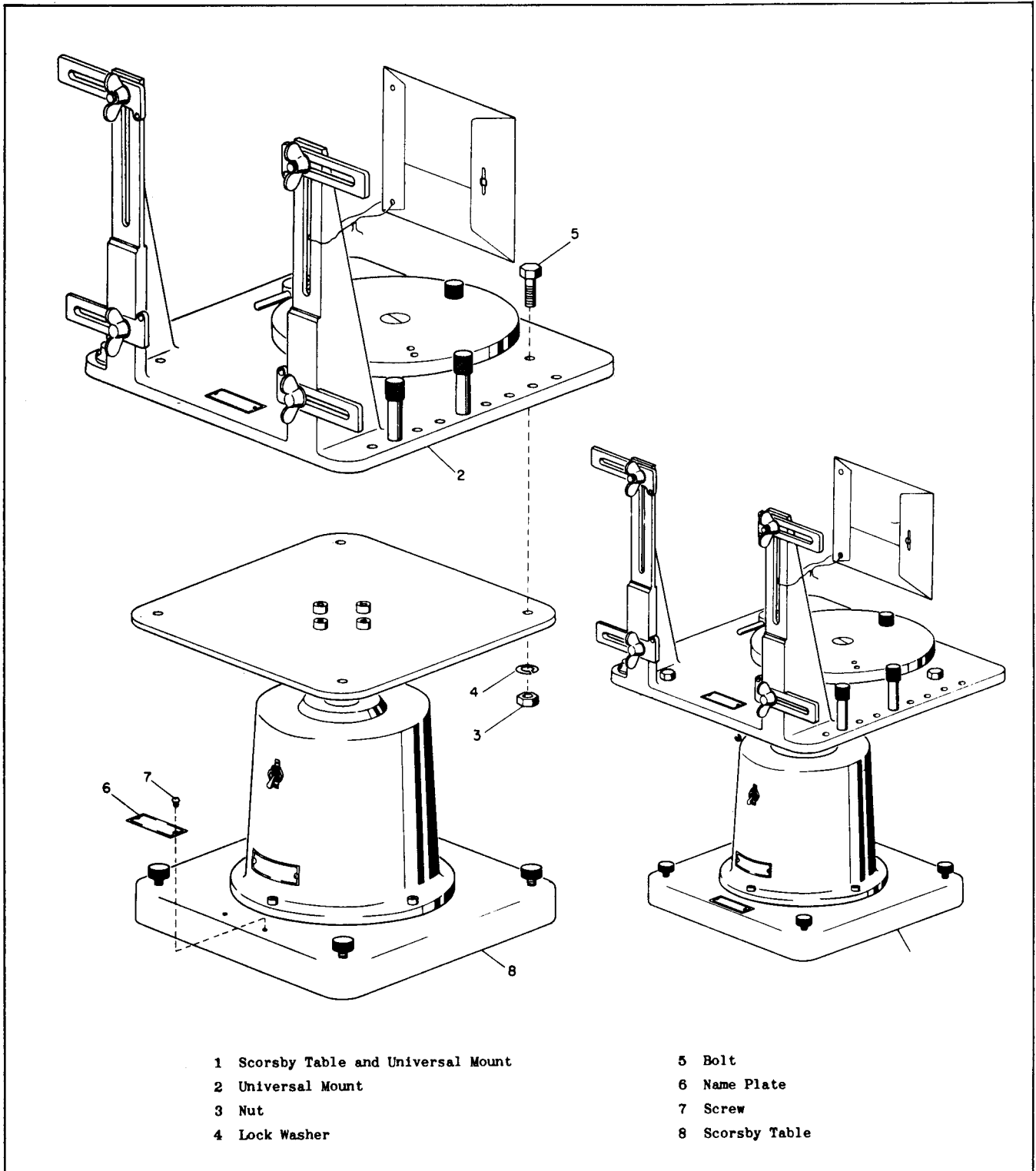

Figure 6-I. Exploded View - Table Scorsby with Universal Mount

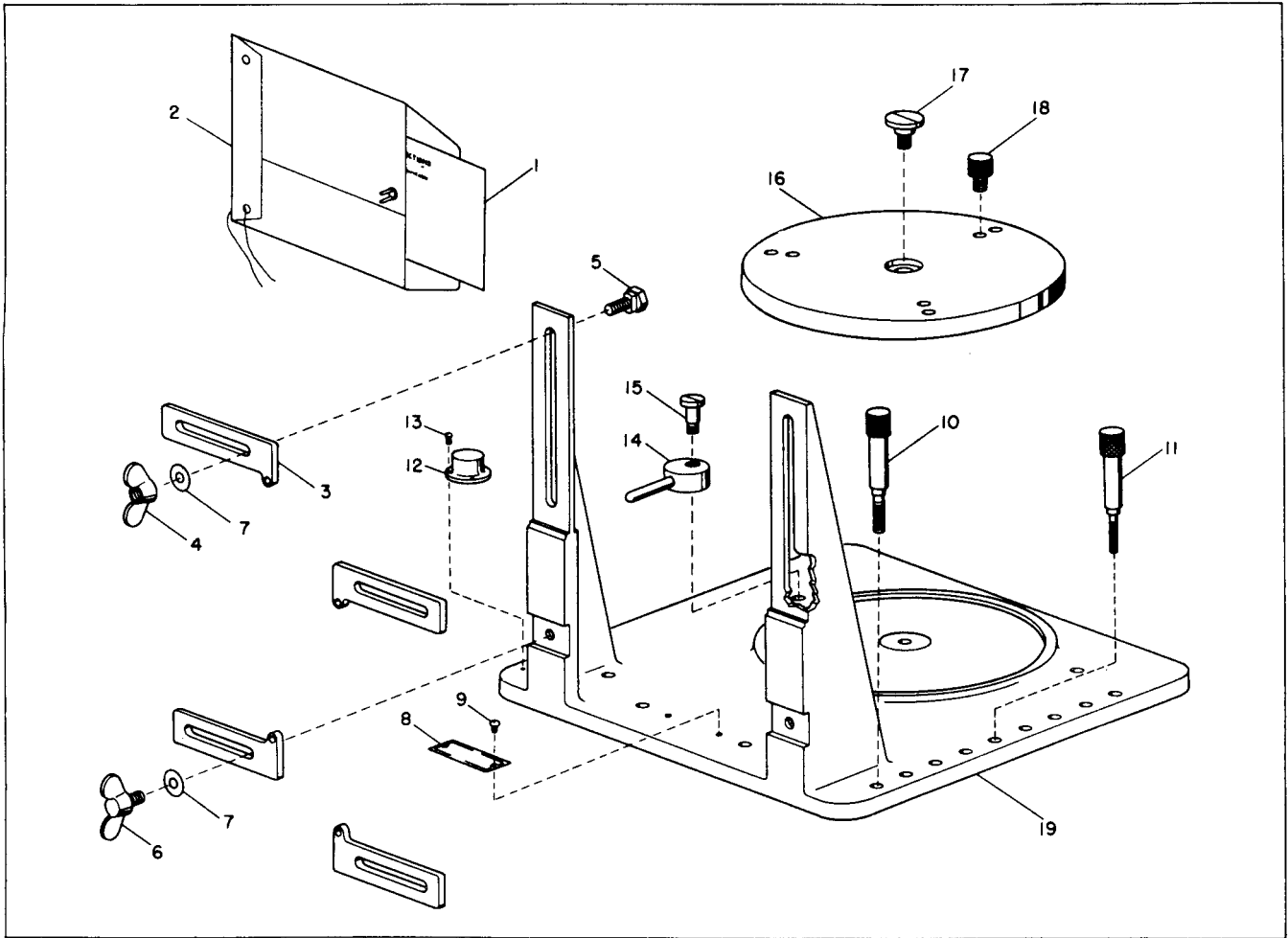
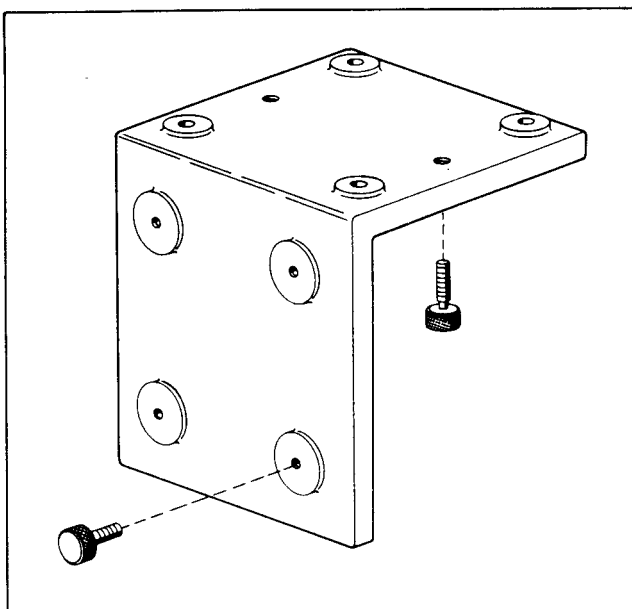

Figure 6-2. Exploded View - Universal Mount



KEY TO FIGURE 6-2

- 1 Instruction Card
- 2 Envelope
- 3 Arm
- 4 Thumb Screw
- 5 Screw
- 6 Thumb Screw
- 7 Washer
- 8 Name Plate
- 9 Screw
- 10 Mounting Screw
- 11 Mounting Screw
- 12 Spirit Level
- 13 Screw
- 14 Camloc
- 15 Screw
- 16 Turntable
- 17 Screw
- 18 Mounting Screw
- 19 Test Table Base

Figure 6-3. Adapter Scorsby T-100945

Revised 25 November 1956

SECTION VII
CALIBRATION

7-1 CALIBRATION.

7-2. No calibration of the Table Scorsby T-100925
is required.

G. H. BECKER,
General, *United States Army*,
Chief of Staff.

Official:

J. C. LAMBERT,
Major General, *United States Army*,
The Adjutant General.

Distribution:

Active Army:

DASA (3)	ARADCOM Rgn (2)	USA Sig Msl Spt Agcy (4)
CNGB (1)	OS Maj Comd (3)	Sig Fld Maint Shops (3)
Tech Stf, DA (1) except CSigO (14)	OS Base Comd (2)	USASSA (15)
Tech Stf Bd (1)	LOGCOMD (2)	USASSAMRO (1)
USAARTYBD (1)	Armies (2)	USASIMSA (10)
USAARMBD (1)	Corps (2)	USARCARIB Sig Agcy (1)
USAIB (1)	GENDEP (2) except Atlanta	JBUSMC (2)
USARADBD (1)	GENDEP (None)	USA Corps (1)
USAAVNBD (1)	Sig Sec, GENDEP (5)	Units organized under following TOE's:
USAATBD (1)	Sig Dep (10)	11-158 (2)
USA Abn, Elet & SPWAR Bd (1)	Ft Monmouth (30)	11-587 (2)
USCONARC (5)	OSA (1)	11-592 (2)
ARADCOM (2)	USAOMC (2)	11-597 (2)
	USA Strat Comm Comd (1)	

NG: None.

USAR: None.

For explanation of abbreviations used, see AR 320-50.

TM 11-4920-209-14 TABLE SCORSBY T100925—1962